

PANELLI®

Italian excellence since 1906



This manual contains basic instructions that must be observed during installation, use and maintenance. This manual must strictly be consulted by the installer and by all qualified personnel who will follow its operation designated by the system manager. Furthermore, this manual must always be available in the place where the machine is used.

IT	Manuale d'uso e installazione elettropompe sommerse e motori elettrici
EN	Use and installation manual submersible electric pumps and electric motors
FR	Manuel d'utilisation et d'installation électropompes submersibles et moteurs électriques
ES	Manual de uso e instalación electrobombas sumergibles y motores electricos
DE	Betriebs- und Installationsanleitung Elektrische Tauchpumpen und Elektromotoren
NL	Handleiding voor gebruik en installatie elektrische dompelpompen en elektrische motoren



Use and installation manual:

The complete manual can be downloaded in .pdf format from the company's website www.panellipumps.it by framing the QR code with the camera of your smartphone.

TO BE COMPLETED BY THE CUSTOMER

Customer:

Place of installation:

Date of installation:

Electric pump / motor model:

Serial number:

Electric pump capacity:

Head (m):

Absorbed power (kw):

Voltage (V):

Frequency (Hz):

Phase:

ATTENTION:
PLEASE COMPLETE ALL THE ABOVE FIELDS
FOR BETTER PRODUCT TRACEABILITY.

Instructions and warnings

These operating instructions contain important information and warnings. Please read them before proceeding with assembly, the electrical connection and commissioning. Carefully read the instructions below prior to installation and use.

We decline all liability in case of an accident or damage due to negligence or failure to observe instructions described in this booklet or in conditions other than those indicated on the nameplate. We also decline all liability for damage due to improper use of the electric pump.

Installation must be carried out by competent and authorised installers.

Before starting any work on the pump, make sure that the power supply has been disconnected and that it cannot be unintentionally reconnected.

if the supply is damaged, it must be replaced by a special cord or assembly available from the manufacturer or its service agent.

Overview

The electric pump was built according to the most advanced and recent techniques, in full compliance with the standards in force and is subjected to permanent quality control. This manual will help you understand how it works and its possible applications.

The user manual contains important recommendations that are necessary for correct and economical operation.

These recommendations must be complied with to ensure reliability and durability and to avoid the risk of accidents deriving from improper use.

The electric pump must not be used outside the limits indicated in the technical specifications.

The indications regarding the nature, density, temperature and flow rate of the pumped liquid, the rotation speed, pressure, motor power and all other instructions in this manual or the documentation attached to the contract must be complied with.

The nameplate indicates the range, the main service specifications and the serial number. It is important to provide this information when requesting help or assistance and when ordering spare parts.

Safety regulations

This manual contains basic instructions that must be observed during installation, use and maintenance. This manual must strictly be consulted by the installer and by all qualified personnel who will follow its operation designated by the system manager. Furthermore, this manual must always be available in the place where the machine is used.

Risks deriving from non-compliance with safety regulations

Failure to comply with the safety regulations can cause physical and material damage as well as possible environmental pollution. Failure to comply with the safety regulations can invalidate all warranty rights.

Below are a few examples of what failing to comply with these regulations can cause:

- ▶ malfunctioning of the main functions of the machine or system.
- ▶ compromised maintenance.
- ▶ electrical, mechanical or chemical injuries.

All the safety instructions in this manual must be complied with, as well as the national laws regarding accident prevention and the in-house rules on system use and occupational safety.

Before installation, make sure that the power supply is earthed and compliant with the regulations. They are not suitable for pumping flammable liquids or to be used in environments with a risk of explosion. Avoid contact between the power supply and the liquid to be pumped. Do not modify the components of the electric pump.

Under no circumstances must the electric pump be held or carried from the power cable.

Safety instructions for inspections, maintenance and service activities

The person in charge must make sure that all maintenance, inspections and assembly activities are carried out by qualified and authorised personnel.

Before proceeding, personnel **must** be aware of the contents of this manual. As a general rule, all works on the machines must only be carried out when the machines are completely stopped. It is absolutely necessary to comply with the stopping procedure described in this manual. The pumps carrying fluids that are hazardous to health must be decontaminated. Once the works are completed, all the safety and protection devices must be refitted and put back into operation.

PRELIMINARY INSPECTIONS

Remove it from the packaging and check its integrity. Also check that the nameplate data are those intended. In the case of any anomaly, contact the supplier immediately, indicating the type of defect.

ATTENTION: if in doubt about machine safety, do not use it.

CONDITIONS OF USE

The electric pump must be used in compliance with the following conditions:

- ▶ Max. temperature of the liquid: + 30°C
- ▶ Voltage variation allowed: +/- 10%
- ▶ Protection rating: IP 68
- ▶ In the case of special executions (PE2+PA windings), the water temperature can reach 50°C (application on request)

Modification and fabrication of spare parts by the customer

Reconstruction or modification of the machine must always be approved by the manufacturer in advance. Original spare parts and accessories supplied by the manufacturer guarantee safety. Under no circumstances will the manufacturer be held liable for consequences deriving from non-original spare parts being used!

1. DELIVERY AND STORAGE

1.1 Delivery

The submersible pumps are supplied in their original packaging, which they must remain in until they are to be installed.

Take care not to bend the pump when it is no longer packed as this could cause it to be misaligned and damaged. The pump must not be exposed to unnecessary shocks and collisions.

1.2 Storage and handling

Storage temperature:

Pump: -10°C to +50°C

The pump must not be exposed to sunlight. If the pump has not been packaged, it must be stored horizontally, adequately supported, or vertically, to prevent possible misalignment. When stored, the pump can be supported as shown in **Fig. 1**.

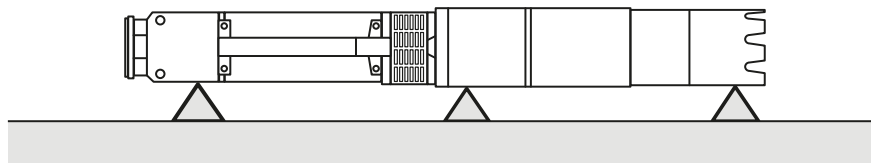

Fig .1

If the pump is not used in a vertical position, both the pump part and the motor must be supported. Note that the centre of gravity will vary with the type of pump.

However, when installed, the motor must be checked to verify it is still completely full (see filling instructions on **pag. 28**).

2. GENERAL INFO

2.1 General description

Submersible electric pumps are multistage pumps that run in anticlockwise rotation (when looking from the delivery side), directly coupled to special submersible motors (according to NEMA standards).

2.2 Applications

These submersible electric pumps are designed for a wide range of applications, such as water supply for private homes, aqueducts and industries. They are indispensable if the groundwater level decreases and for increased pressure.

Fully immerse the pump below the water level when you install it both horizontally and vertically. See paragraph [3.1 Positioning limits](#).

2.3 Pumped liquids

Clean liquids, compatible with the construction materials of the pump, without solid particles or fibres. The maximum content of sand in the water is specified in the catalogue. A higher concentration of sand will shorten the life cycle of the pump and increase the risk of seizing. If the pump is used to pump liquids with a greater density than water, a motor with proportionately greater power must be used.

ATTENTION: the pump must not run dry.

3. INSTALLATION / PREPARATION

Installation may be a rather complex activity. It must therefore be carried out by competent and authorised installers.

ATTENTION: during installation, apply all the safety provisions set forth by the competent bodies and based on common sense. Do not underestimate the risk of drowning if the installation is to be carried out at a certain depth inside a well. Make sure that there is no risk of toxic fumes or harmful gases in the work atmosphere. In the case of welding operations, adopt all precautions to avoid explosions. Bear in mind the risk of infection and the hygiene-sanitary precautionary regulations.

3.1 Positioning limits

If the pump is installed in a position that is accessible to people, any possibility of contact between them and the joint must be avoided, by, for example, fitting it with a protective screen.

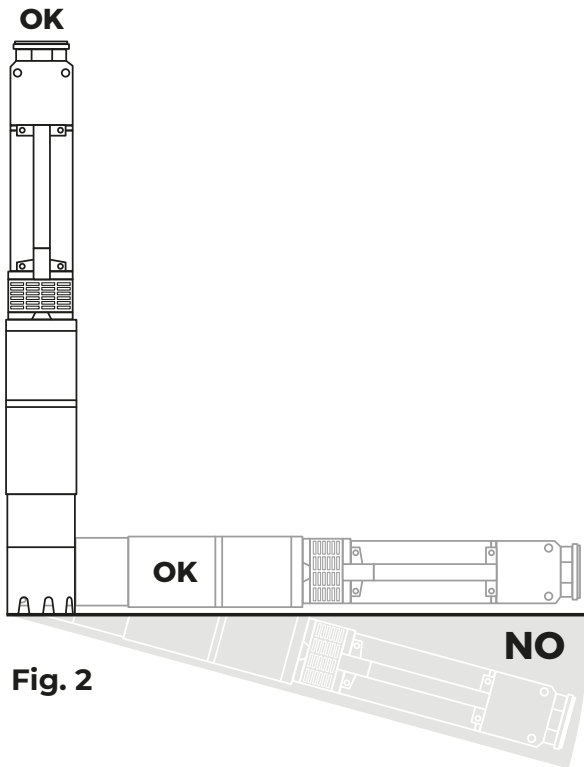

Fig. 2

The pump is suitable for both vertical and horizontal installation but **never** with a downward inclination, **Fig. 2**

When the installation is horizontal it is advisable to set up a cooling jacket and, where possible, bronze bushings must be used on the pump and motor.

Note: The intake system must always be submerged during operation. In special conditions, it may need to be submerged deeper, depending on the work point, temperatures and NPSH of the pump.

3.2 Pump/motor diameter Check the maximum diameter of the pump and pump with motor in the technical catalogue. Check that the well has no restrictions or obstacles for the pump to descend.

3.3 Check valve on the delivery pipe

The pump incorporates a check valve in the delivery inlet. However, particularly in applications where the pump feeds a pressurised distribution network directly, it is advisable to install another check valve on the delivery pipe at no more than 10 metres from

the minimum level of the well (if this is not known, use the delivery inlet as a minimum level). Its presence attenuates the hydraulic shocks caused by start-ups and stops.

4. ELECTRICAL CONNECTIONS



ATTENTION: it is the installer's responsibility to make the connection in accordance with the regulations in force in the country of installation. Before making the connections, make sure that there is no voltage at the ends of the line conductors. Check that the nameplate info and the nominal line values correspond. Make the connection while ensuring that there is an effective earth circuit in place. It is recommended to install a differential switch. The user is responsible for protecting the motors. Pump repairs by unauthorised personnel will invalidate the warranty.

ATTENTION: any tampering can deteriorate performance and pose a risk to people and/or property.

4.1 Overview

The connections must be carried out by an authorised electrician according to the regulations in force.

The supply voltage and current appear on the motor nameplate and must be kept in the electrical panel. The motor must be earthed and connected to the electrical panel

4.2 Checking the direction of rotation

Once connected to the power supply, determine the direction of rotation as follows:

1. Start the pump and check the delivered head with the gate valve not fully closed.
2. Stop the pump and invert the connections of two phases (only for the three-phase version).
3. Start the pump and repeat step 1 with the gate valve in the same position.
4. Stop the pump.

Compare the results obtained after performing steps 1 and 3.

The correct connection is that with the highest head.

Note: The pump cannot be started until the intake system has been fully submerged.

5. INSTALLING THE PUMP



Before starting any work on the pump or motor, make sure that the power supply has been disconnected and that it cannot be unintentionally reconnected

5.1 Assembling the pump with motor

Align the pump on the motor and insert the motor shaft into the pump shaft joint without the coupling being forced. Tighten the screws or nuts that secure the pump-motor flanges diagonally, to a tightening torque as indicated in the table below.

Type of motor	Screw	Standard A2-70 tightening torque (Nm)
4" Motor	M8	26
6" Motor	M12	82
8" Motor	M16	200
10" Motor	M16	200

IT

EN

FR

ES

DE

NL

5.2 Delivery pipe

If the pump is already coupled to the delivery pipe and a pipe chain wrench is used, the pump must only be tightened by grasping it from the delivery inlet.

The threaded pipes must be connected to contain any unscrewing action due to the pump being started-up/stopped. The pipe thread that screws to the pump must not be longer than the pump thread. After screwing the pipe into the delivery inlet, tighten the screw to prevent the first pipe section from loosening. Lower the electric pump into the well using the supporting rope, see **Fig. 3**

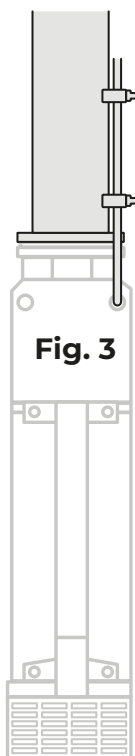

Fig. 3

5.3 Cable layout



Clamps must be applied every 3 metres to secure the cable on the supporting rope or on the delivery pipe. Use plastic ties as indicated in **Fig. 4**. Once the cable has been secured, cut the clamp protrusion. If the pipe is made of plastic, leave the electric cable and the supporting rope loose so as to prevent the pipe from elongating due to the weight of the water in it and tearing the power cable. In the case of flanged pipes, the clamps must be applied before and after the flanges.

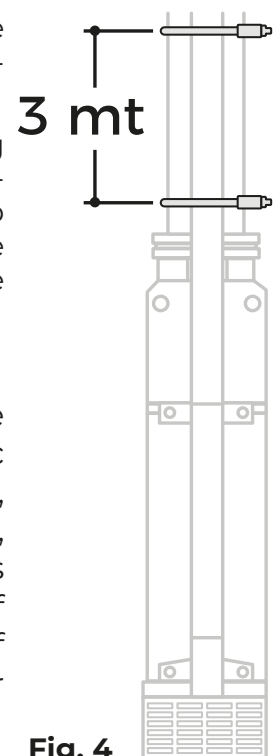

Fig. 4

5.4 Inserting the pump

It is recommended to check that the well is not obstructed along its entire length. Lower the pump into the well, without damaging the electric cable. Set the crane fitted with a hoist and sufficient capacity to support the weight of the electric pump and the pipe full of water, in line with the vertical line of the well.

NEVER INSTALL THE ELECTRIC PUMP BY HAND OR USING THE CABLE TO SUPPORT IT.

5.5 Installation depth The dynamic level in the well must ensure that the pump intake system is covered, see paragraph 3.1

Positioning limits **The minimum safety margin must be 1 metre.**

6. START-UP



Once installed and submerged, the pump can be started with the gate closed by 1/3. Check the direction of rotation as described in paragraph 4.2 Checking the direction of rotation.

If there are impurities in the water, the gate valve must be opened gradually until the water begins to clear up. The pump must not be stopped before the water is completely clean again, because otherwise the various parts of the pump and the check valve could be damaged. If the pump flow rate is higher than that of the well, we recommend using equipment that protects against dry running. If there is no protection to prevent dry running, the water level will drop below the intake system and the pump will draw in air. This will eventually cause damage due to insufficient cooling and lubrication.

7. MAINTENANCE AND ASSISTANCE

The pumps do not require special maintenance. All pumps are easy to be serviced.

Before starting any work on the pump or motor, make sure that the power supply has been disconnected and that it cannot be unintentionally reconnected.

7.1 REGULAR INSPECTIONS

Before proceeding with the checks, make sure that the voltage is disconnected and there is no possibility of an accidental connection. It is advisable to periodically check:

- ▶ The condition of cables and cable glands, especially at the attachment points
- ▶ The wear of the impellers, which will reduce efficiency; contact the dealer for replacement
- ▶ Cleanliness of the intake grid.

Using the pump in hard or very sandy water can shorten the life cycle of the equipment.

8. DISPOSAL



Lo smaltimento di questo prodotto, o parte di esso, deve essere effettuato usando i sistemi locali, pubblici o privati, di raccolta dei rifiuti

4" SUBMERSIBLE ELECTRIC MOTORS IN OIL BATH

The 4" submersible motors work in wells with water with a temperature that does not exceed 30°C with a PH ranging between 6.5 and 8.0. The top-up liquid is a dielectric fluid called white

oil, approved by the American FDA and other pharmacological institutes around the world. The coupling dimensions and the flange comply with the NEMA standard, as these submersible motors are specifically designed to work with submersible pumps with the same coupling dimensions. The power supply can be single- or three-phase. The single-phase range starts from 0.37 kW (0.5 HP) up to 2.2 kW (3 HP), whereas the three-phase range is from 0.55 kW (0.75 HP) to 7.5 kW (10 HP). The motors are suitable for inverter operation. Submersible motors are usually used in vertical installations. However, the motors can be installed horizontally, always after prior confirmation from our technical department and the global evaluation of the required application. The motors can be installed in 4" wells with a maximum depth of 150 metres. The 4" submersible motors in an oil bath are supplied with lubrication liquid and only require a precautionary level check when installed. An inspection is advisable when there is reason to believe that the filling level is insufficient due to:

- ▶ leaks in transit
- ▶ storage in very hot environments and/or subject to great temperature fluctuations

The 4" electric motors guarantee reliable operation in wells with a diameter that is equal to or greater than 4". The axial and radial bearings are lubricated with the oil and allow maintenance-free operation. The pressure compensation inside the motor is guaranteed by a special diaphragm.

ADVANTAGES:

- ▶ Stator in oil bath
- ▶ Cable material compliant with drinking water standards
- ▶ Sand protection and mechanical seal to allow excellent operation in the presence of sand in the well
- ▶ Designed for excellent efficiency with low operating costs.

CABLE CONNECTION



Joining the length of cable coming out of the motor and that which will have to reach the control panel is particularly delicate and must be carried out with great care, by expert personnel.

Always work without voltage present. Make sure that the power supply cable is of suitable quality and of adequate section in relation to its length and motor power. For a correct choice, refer to the technical tables in the TECHNICAL NOTES - INFORMATION chapter, in the general catalogue.

Single-phase motor:

These motors are fitted with a 220/230 V capacitor.

- 1 - BLACK (COMMON)
- 2 - BLUE / GREY (START-UP)
- 3 - RED / BROWN
- 4 - CAPACITOR

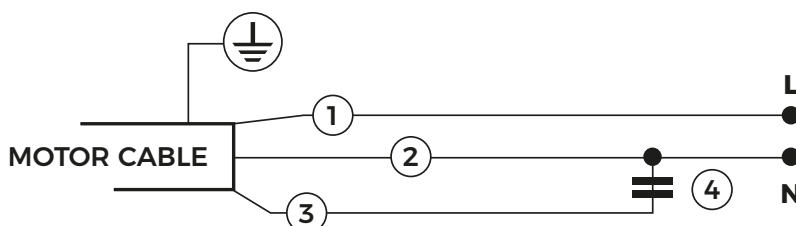

Three-phase motor: direct start-up at the nominal voltage – connect the power cable and check the direction of rotation of the pump.

6"/ 8"/10" REWINDABLE SUBMERSIBLE ELECTRIC MOTORS IN WATER BATH

This assembly and use manual is an integral part of the rewindable submersible motor and describes its safe and adequate use in all operating stages.

Keep the assembly and use manual in an accessible place near the motor so that it can be consulted when necessary. Pass on the assembly and use manual to subsequent users of the motor.

This assembly and use manual only applies to the motors described herein.

Submersible motors in a water bath, rewindable in PPC/PE or PE2+PA, are of particularly robust construction and able to operate for a long time without any maintenance. PE2+PA motors are suitable for running with a VFD frequency converter (minimum frequency allowed: 30 Hz).

OPERATING FEATURES

Available in two versions: 50/60 Hz

Maximum variation allowed on the motor nominal voltage: $\pm 10\%$

Maximum number of start-ups per hour: (6": 15) – (8": 10) - (10": 10) - Maximum water temperature 30°C, 50°C with PE2+PA winding.

Motor axial thrust 6": 16,000 N from 4 to 15 kW – 25,000 N from 18.5 to 37 kW

Motor axial thrust 8": 45,000 N from 30 to 110 kW

Motor axial thrust 10": 60,000 N from 75 to 184 kW

MODELS

6" Motor from 4 to 37 Kw - 8" Motor from 30 to 110 kW - 10" Motor from 75 to 184 kW

SPECIAL EXECUTIONS

Double output motors for star-delta start-up - Execution in AISI 304, AISI 316, Duplex stainless steel.

STARTING UP THE ELECTRIC MOTOR



Motor check prior to assembly

If there are visible leaks or if the motor is more than one year old (for example, if it is used again or in the event of prolonged storage), check the filling level of the motor before assembly.

The following tools are required for the checks:

- ▶ Insulation measuring instrument: 500 V DC with test
- ▶ Determine how old the motor is based on the nameplate

CHECKING THE MOTOR FLUID



FILLING THE MOTOR

6" - 8" - 10" SUBMERSIBLE ELECTRIC MOTORS ARE WATER-COOLED, THEREFORE THE MOTOR IS PRE-FILLED WITH WATER-BASED EMULSION.

However, when installed, the motor must be checked to verify it is still completely full. For this purpose, set the electric pump in a vertical position.

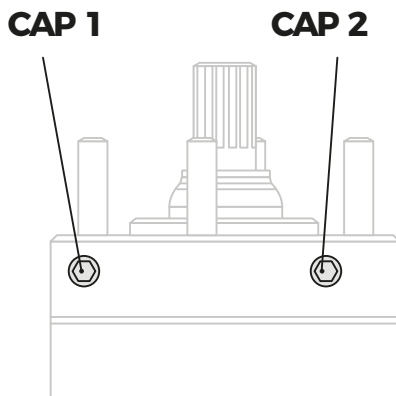

- ▶ Unscrew caps **1** and **2** (see drawing).
- ▶ Top up with clear water through hole **1**, until it comes out of hole **2**.
- ▶ Wait a few minutes and repeat the step with utmost care, topping up several times, so that the motor is bled from all the air, thereby filling the motor with water. Screw the 2 caps back on.

After this step, the electric pump must be kept upright so as to prevent even the slightest water leak from the motor.

PRECAUTION

- ▶ Motor damage due to being filled insufficiently.
- ▶ Fill the motor with sufficient fluid.
- ▶ When filling and emptying the motor, wear protective goggles and gloves.
- ▶ Fill the motor with clear drinking water.
- ▶ Do not use distilled water.

EXTENDING THE MOTOR CABLE

- ▶ Damage to the motor if the cable is damaged.
- ▶ Make sure the motor cable does not touch sharp edges.
- ▶ Protect the cable with a cable protection bar.
- ▶ Use only extension cables and insulating material that is suitable for use (in particular drinking water) and allowed for the temperatures reached in the device in question.
- ▶ The installer is responsible for the correct choice and sizing of the cable.
- ▶ Lay the cable along the pump.
- ▶ Connect the earth conductor in a workmanlike manner
- ▶ Protect the cable connection area against water penetration (heat shrink sleeves, sealing materials or ready-made cable gaskets).

MEASURING INSULATION RESISTANCES

The measurement must be taken with an insulation measuring instrument (500 V DC) before and while immersing the unit mounted in the place of use.

Before immersing, connect a measurement cable to the earth conductor.

- ▶ Make sure the contact areas are clean.
- ▶ Connect the other measurement cable in series with each wire of the connected motor cable.
- ▶ The insulation resistance is indicated in the insulation measuring instrument.

Minimum insulation resistance (ambient temperature 20°C) with extension:

- ▶ **with a new motor > 50 MΩ**

► with a used motor > 20 MΩ

Minimum insulation resistance (ambient temperature 20°C) without extension:

► with a new motor > 500 MΩ

► with a used motor > 50 MΩ

ELECTRICAL CONNECTION OF THE MOTOR



Risk of death from electric shock.

Before carrying out the electrical connections of the motor, make sure that the system is completely voltage-free and that no one can inadvertently reactivate the voltage during the works.

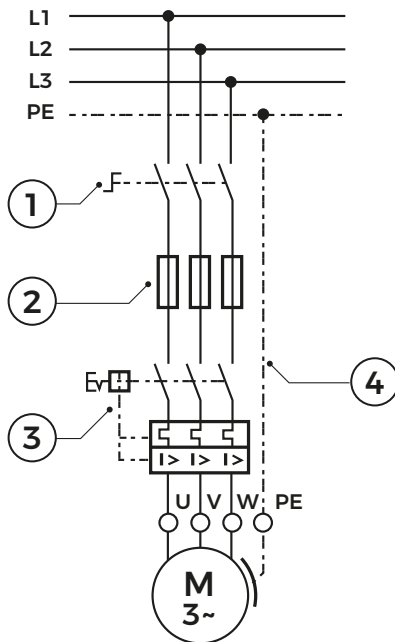

- Install an external mains switch **(1)** to disconnect the power to the system.
- Install valves **(2)** on site for every single phase.
- Install a motor protection circuit breaker **(3)**
- Install an emergency switch-off switch, if necessary, for the intended use.
- Connect the motor to earth **(4)**

STAR DELTA MOTOR ELECTRICAL CONNECTION

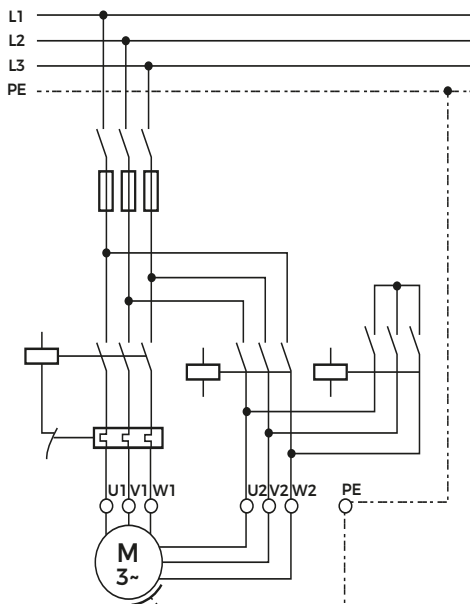

ENSURE SUFFICIENT MOTOR COOLING

Make sure that the coolant rate along the motor is sufficient.

Make sure that the short motor cable is always surrounded by liquid, which ensures cooling.

If it is not possible to achieve the required minimum coolant rate (for example, if the well inlet is above the motor or in the case of large diameter wells): Fit a cooling pipe

Make sure that the cooling pipe fully encircles the motor and the opening for the pump water inlet.

MOTOR START-UP



Start up the motor from the electrical panel mains switch. After switch-on, measure the following variables:

- ▶ motor operating voltage in every phase
- ▶ mains voltage with the motor running

Switch off immediately if:

- ▶ the nominal voltage shown on the nameplate is exceeded
- ▶ voltage tolerances higher than 50Hz:-10% at +6% / 60Hz:±10% are measured on the motor, compared to the nominal voltage
- ▶ there is a risk of dry running
- ▶ every three currents and a motor current deviates more than 5% of the average value

USING THE MOTOR WITH FREQUENCY CONVERTER (VFD)

Make sure that the motor current does not exceed the nominal motor current indicated on the nameplate at all operating points of the setting range.

Adjust the VFD so as to maintain the limit values of the nominal motor frequency equal to 30 Hz min and the nominal frequency of the motor (50 or 60 Hz) max.

If a VFD is used, limit the motor voltage peaks to the following values:

voltage increase 500 V/ μ s max, peak voltage 1000 V max.

Make sure that the time to reach full capacity from 0 to 30 Hz and the relaxation time from 30 to 0 are equal to a maximum of one second.

When sizing the cables, consider the drop in voltage with additional filters.

Make sure that the necessary coolant rate is maintained along the motor, even when using a VFD.

PT 100 Reading with multimeter and use with VFD

PT100 reads by means of a multimeter. The PT100 contains a platinum thermoelement that changes its resistance according to the temperature: at 0°C, the nominal resistance of the PT100 is 100 Ω ; at 100°C, the resistance becomes 138.5 Ω . Therefore, you can determine the temperature of the device which the PT100 is connected to and measure its resistance with a multimeter.

BANDAGE FOR SUBMERSIBLE PUMPS



A submersible cable bandage that is applied correctly (with taut, watertight connectors) helps extend the life cycle of the motor, whereas a loose bandage causes premature damage to the windings. Select the splice kit (connectors) according to the thickness of the wires to be spliced.

1 - Cut the motor connector cables to different lengths.

2 - Make the staggered cuts described in the previous point match the lengths and corresponding colours of the cables to be connected.

3 - Before splicing the cables, do not forget to place every heat shrink pipe in each of the motor connector cables. Remove part of the outer sheath or sheath that acts as mechanical protection from the submersible flat power cable.

When carrying out this step, it is very important not to damage the individual insulation of the wires.

4 - Remove sufficient individual insulation (from both the motor connector cables and the submersible cable) to allow both ends to be joined via the butt connectors.

5 - Splice each pair of corresponding cables via the butt connectors.

Make sure this union is very secure. Clean this surface with alcohol and let it dry.

6 - Place the heat shrink pipe over the splice made, leaving the butt connector at the centre. Apply heat to the outside of the pipe, do so evenly from the centre to the sides, so as to prevent bubbles from forming. The pipe will immediately reduce its diameter to adapt to the cable thickness and seal the ends.

Let it cool down. Repeat this step until you have completed the procedure on all three wires.

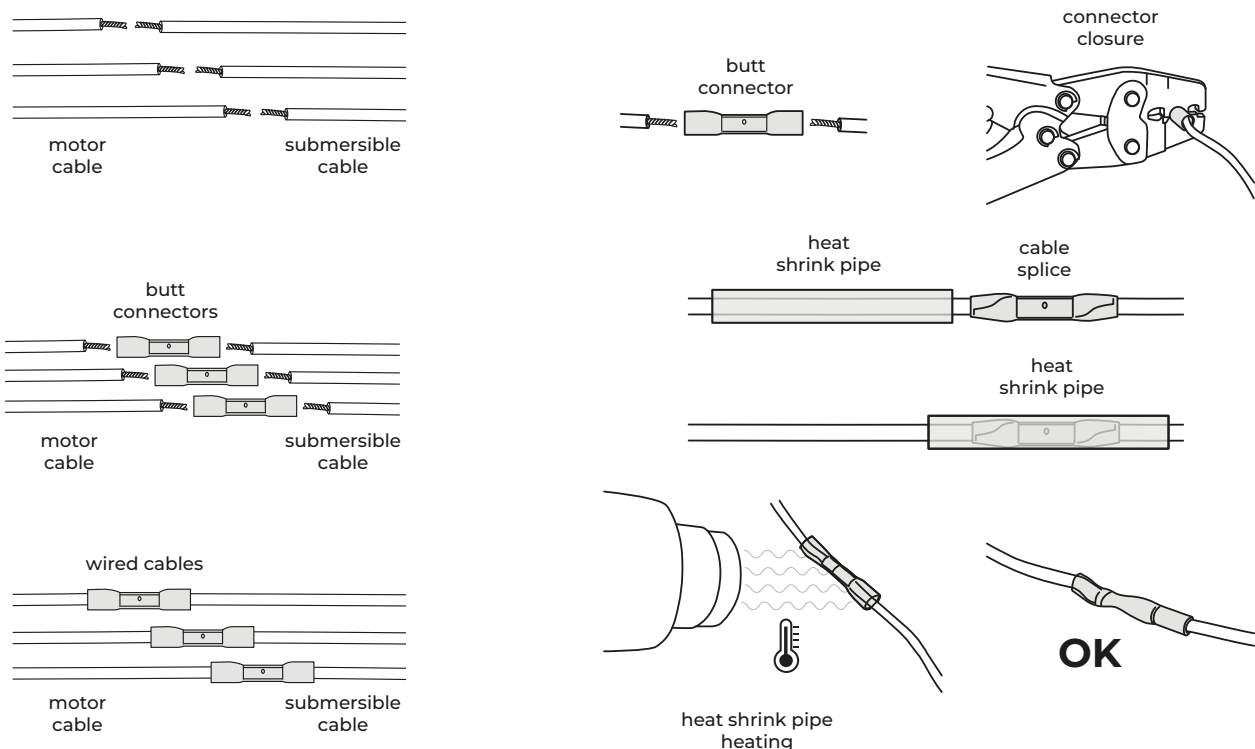

Note: it is important to note that similarly to the submersible flat cable, you can find that a few manufacturers of connection cables use two layers that cover each conductor – the inner layer is the electrical insulation (the heat shrink pipe must be applied to this layer) and the second layer acts as mechanical protection.

7 - Wrap each cable joint with a layer of self-vulcanising rubber insulating tape; this layer must cover 5 cm in excess of each end of the heat-shrink pipe. Then apply two layers of **SCOTCH 33** tape or similar, for external protection (exceeding 5 cm at each end of the vulcanising tape). Make sure you apply the tape as taut and airtight as possible.

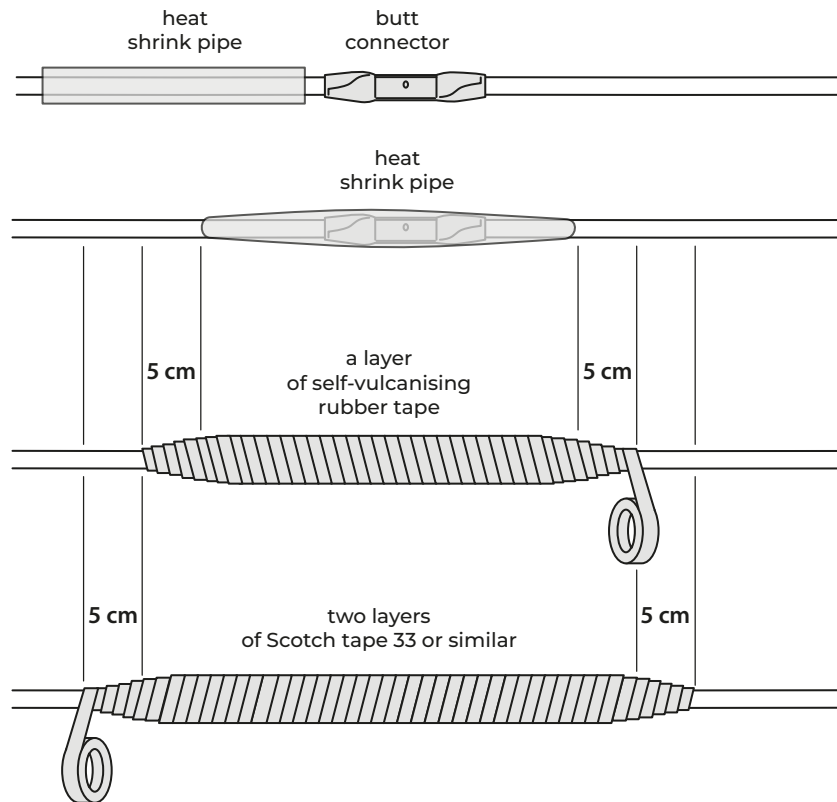

8 - Lastly, for the external mechanical protection of the three joints previously made, join the three cables and cover them with two layers of **SCOTCH 33** adhesive tape or similar.

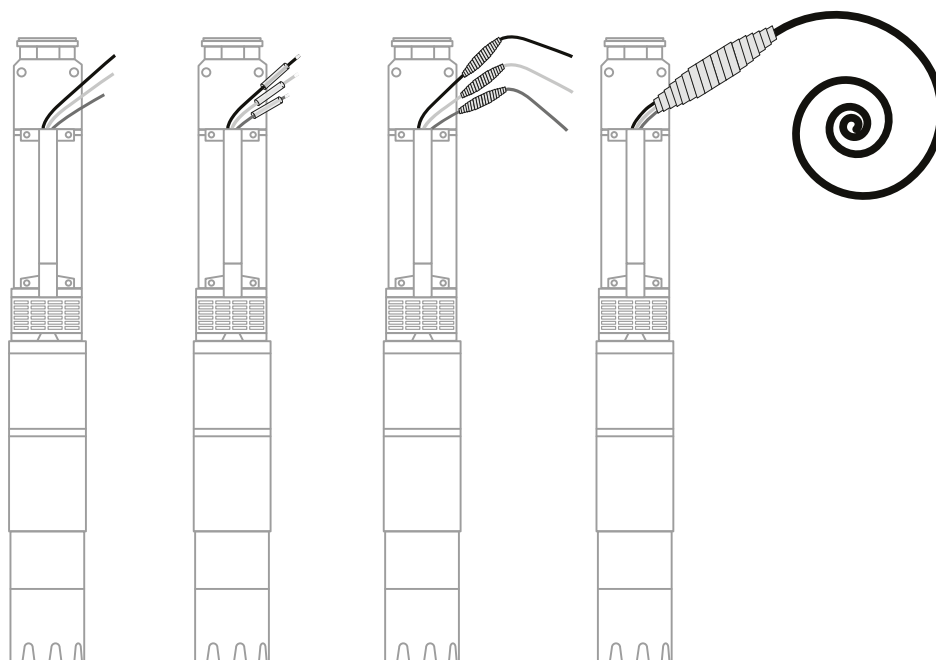

IT

EN

FR

ES

DE

NL



Declaration of conformity

The manufacturer: Panelli s.r.l.

Via Rana n.63, Zona Industriale D5
15122 Spinetta Marengo, Alessandria - ITALY
tel.: +39 0131 619506
fax: +39 0131 619017
web: www.panellipumps.it

declares under his own responsibility that the borehole pumps:

4" models: 95 PR - 95 PRX - 95 SX - 95 REC

6" models: 140 PR - 140 PRX - 140 PS - 140 PSX - 140 RHX - 140 SX - 140 REC

8" models: 180 RHX - 180 SX - 180 REC

10" models: 230 SX - 230 REC

12" models: 270 SX - 270 REC

14" models: 330 SX

are in conformity with the following European Directives:

- 2006/42/CE (Directive Machines)

And are in conformity with:

- EN 9906 – Rotodynamic pumps – Hydraulic performance acceptance test – Grades 1,2,3
- EN 809 – Pumps and pump units for liquids – Common safety requirements
- EN 12162 – Liquid pumps – Safety requirements – Procedure for hydrostatic testing

The manufacturer declines all responsibilities in case of use not shown in the instruction's manual supplied with every pump. The technical file is available at the company headquarters.

Spinetta Marengo (AL), 08/10/2024

The Legal Representative
Ing. Francesco Sorio



Declaration of conformity

The manufacturer: Panelli s.r.l.

Via Rana n.63, Zona Industriale D5
15122 Spinetta Marengo, Alessandria - ITALY
tel.: +39 0131 619506
fax: +39 0131 619017
web: www.panellipumps.it

declares under his own responsibility that the submersible motors single-phase and three-phase:

4" models: P4005 - P4007 - P4010 - P4015 - P4020 - P4030 - P4040 - P4055 - P4075 - P40100 - PWX4005 - PWX4007 - PWX4010 - PWX4015 - PWX4020 - PWX4030 - PWX4040 - PWX4055 - PWX4075 - PWX40100

6" models: P605 - P607 - P610 - P612 - P615 - P617 - P620 - P625 - P630 - P635 - P640 - P650

8" models: P840 - P850 - P860 - P875 - P890 - P8100 - P8125 - P8125 - P 8150

10" models: P10100 - P10125 - P10150 - P10175 - P10200 - P10225 - P10250

12" models: P12200-2P - P12250-2P - P12300-2P - P12350-2P - P12400-2P - P12150-4P - P12180-4P - P12200-4P - P12230-4P - P12250-4P - P12300-4P

are in conformity with the following European Directives:

- 2006/42/CE (Machines directive)
- 2014/30/CE (EMC directive)
- 2011/65/CE (RoHS)

The manufacturer declines all responsibilities in case of use not shown in the instruction's manual supplied with every pump. The Technical file is available at the company headquarters.

Spinetta Marengo (AL), 08/10/2024

The Legal Representative

Ing. Francesco Sorio



Panelli s.r.l.

Registered office: 37047 San Bonifacio (VR) ITALY - Via E. Fermi, 7

Production unit: 15122 (Alessandria) ITALY Via Rana , 63/65 – Z.I D5 - Spinetta Marengo

Phone : + 39 0131 619506 - Fax : + 39 0131 619017

Email : info@panellipumps.it Web: www.panellipumps.it

Company subject to the management and coordination of **PEDROLLO GROUP s.r.l.**